

Tech Tips

- Introduction
- Easy installation of New Flex Pipe
- Remove APT Scuff Guard
- Where to cut a TCI 3950 for repair
- How to identify TCI 3950 Nuts
- Double Wall Fiberglass Variations
- Communication with Corrugated Ducted Systems
- Eccentric Terminations
- How to do a Remote Fill setup
- DAS: Diversified Aqua Seal –When it's too wet to work
- DAG: How to setup the DAG Applicator Gun
- DAG III: How to setup the DAG III Applicator Gun



Introduction to Tech Tips

The intent of the Tech Tips section is to provide some “extra” insight into how to make repairing penetration fittings easier & more efficient.

- Most of the information presented in this section has been compiled from years of research and hands on work with these products.
- If you have a “Tech Tip” that you feel should be in this manual, please pass it along to us for review.

Easy installation of New Flex Pipe

When installing new pipe in an existing Total Containment SP 4500 4” corrugated ducting system it is advisable to spool the pipe off the roll in the fashion described in the picture to the right. This works for The European style pipes as well as the domestic flex pipes.

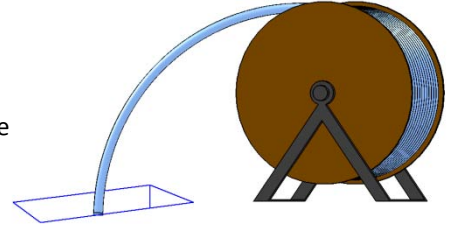

Remove APT Scuff Guard

APT Pipe has a Nylon 12 Scuff Guard as the outermost cover on this style of double wall piping. The Scuff Guard must be removed for proper installation and sealing of the XP double wall pipe when installing the product into an existing system. DPM’s products are sized to seal to the pipe without the scuff guard. The scuff guard is specified as being .025 +/- .030 thick. See the table below reproduced from APT’s literature. Note that the single wall product offerings do not have a Scuff guard.

Model	I.D. ± 0.010 Primary Layer	O.D. ± 0.020 Primary Layer	O.D. ± 0.030 SC Jacket	O.D. ± 0.030 Scuff Guard	Minimum Bend Radius
XP-100-D	1	1.27	N/A	N/A	36.00"
XP-100-SC	1	1.27	1.47	1.502	36.00"
XP-150-D	1.4	1.7	N/A	N/A	36.00"
XP-150-SC	1.4	1.7	1.9	1.925	36.00"
XP-175-D	1.65	1.95	N/A	N/A	36.00"
XP-175-SC	1.65	1.95	2.15	2.175	36.00"
XP-200-D	2.04	2.45	N/A	N/A	36.00"
XP-200-SC	2.04	2.45	2.65	2.675	36.00"

Remove Scuff Guard

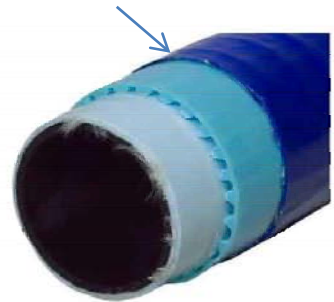

Where to cut a TCI 3950 Boot

When Installing new pipe into existing FB or CB 3950 penetration fittings secured to SP 4500 Secondary Containment the existing boot should be cut back as shown.

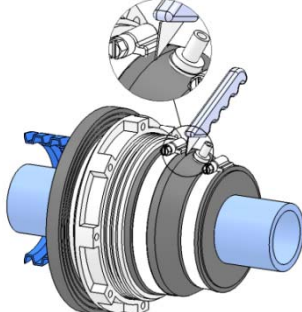

3950 Corrugated Duct Boot

Examples of where to cut off the existing boot

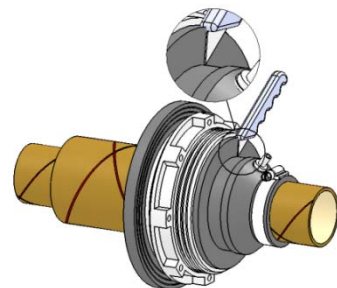

3950 Direct Burial “3 over 2” Boot

DPM's traditional and new Multi-Sync products are designed to encapsulate the band clamp and seal properly to the primary pipe. "FB" stands for a flat surface Bulkhead and "CB" stands for a curved surface Bulkhead. The technician can easily determine whether the penetration being repaired is flat or curved. When ordering repair products the "Flat" or "Curved" feature must be specified as a different bonding ring is provided in the repair kit.

How to ID the TCI 3950 Nuts

Total Containment also offered a coarse thread and a fine thread version of their nut and body in their FB/CB 4950, 4050, 3950 and 3050 penetrations. Those are easily identifiable by observing the shape of the nut. When ordering repair products the "Fine" or "Coarse" pattern must be specified as a different bonding ring is provided in the repair kit. Note there are four bonding ring options –FF (Flat surface Fine thread), FC (Flat Surface Coarse thread), CF (Curved surface Fine thread) and CC (Curved surface Coarse thread). Provide order entry with the correct information and they will get you the correct part. The curved surface seal made by the original TCI penetration included a curved seal on the outside of the sump and a curved spacer on the inside of the sump. As the repairs are made from the inside of the sump, the old spacer must be removed and a new bonding ring is installed in its place. The bonding ring is used on both the traditional and Multi-sync versions of our repair kits.



Fine Thread Nut



Coarse Thread Nut

Double Wall Fiberglass Variations

When repairing double wall fiberglass pipe the FB/CB 3050 or 4050 penetrations were used for 3" FRP and 4" FRP respectively. There are two distinct repair methods used when repairing these products. When the Secondary pipe extends into the sump beyond the fitting, a terminating reducer is used to seal the secondary to the primary for testing of the interstitial. This type of installation is common and is repaired as follows.

Note: In this repair, the reducer to the primary pipe is beyond the repair fitting and separate from the repair boot.

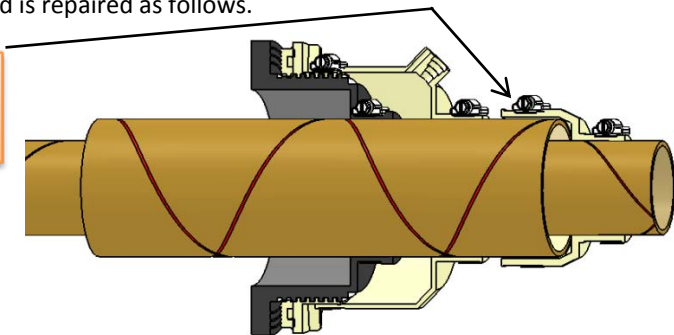

3050 with secondary pipe extending into sump

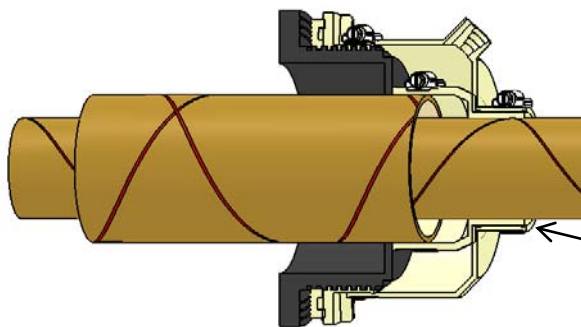

Note: In this repair, the reducer to the primary pipe is inside the repair boot and becomes part of the repair fitting.

Traditional Repair of FB 3050 with pipe terminating inside the fitting

When the double wall fiberglass pipe in the FB/CB 3050 or 4050 is terminated inside the penetration fitting, a donut is often used to seal to the primary pipe. This requires a different repair kit as shown below. The experienced repair technician can readily identify the difference between these repair options.

Eccentric Terminations

Often the primary pipe in a double wall fiberglass system sags so as to be close to one side of the secondary pipe. The picture to the right illustrates the problem. When we first encountered this problem, an installer had a 2x4 across the top of a dispenser pan with a come along trying to jack the primary into the center of the secondary so a terminating reducer could be installed. The system had to be tested and the installer was desperate to get “something to work”. Shortly thereafter DPM developed the following family of Eccentric reducers.

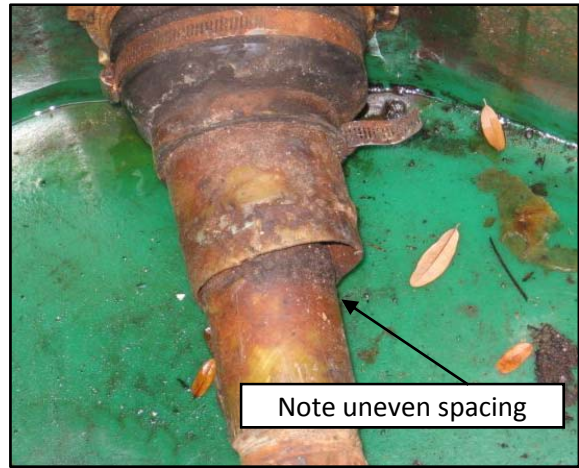

Primary pipe close to one side of secondary pipe



UR6.7 x 4.5E



UR4.5 x 3.5E



UR3.5 x 2.4E



UR3.5 x 3.0E

Additionally it was learned that some sites had no room between the secondary pipe and the Slip by Male or Slip by Female fiberglass fittings. In those instances DPM offered a 3.5 x 3.0 Eccentric so the secondary could be sealed to the fiberglass adaptor.

It should be noted that these split reducers include a ½” drain port. This port is multifunctional. In some instances it is desirable to leave the port open to provide a drain path to a central alarm sensor. The port may be used to loop to the next fitting by just bonding in a ½” tube between fittings. The port may also have an adaptor installed for testing the secondary, or it may be plugged by bonding in one of the RFA-Plugs.



Boots Looped Together with ½” Tubing



Boot with Adapter and Test Assembly



Boot with RFA Plug

A complete line of split terminating and test reducers are available for almost all secondary containment terminating or test reducers. Check the pricing guide for size and cost. Should you need a special or custom reducer, consult the factory for custom manufactured split reducers.

Communication with Corrugated Ducted Systems

Where a corrugated duct system is being repaired with DPM's Traditional or Multi-Sync repair kits, the interstice between the corrugated ducting and the fuel carrying line may need to be open to the sump. You may also need to communicate with another fitting or may need to extend to testing apparatus.

The typical Multi-Sync CDS repair kit uses a Corrugated Duct insert to block off the opening between the inside of the Corrugated ducting and the fuel carrying pipe.

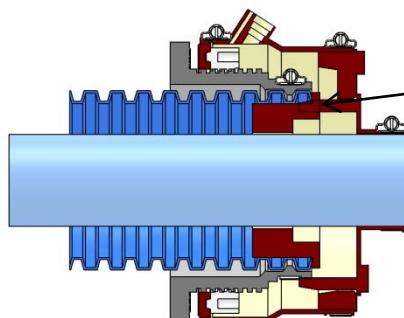

CDI is in place and interstice cannot be tested with this repair

Typical Multi-sync CDS repair

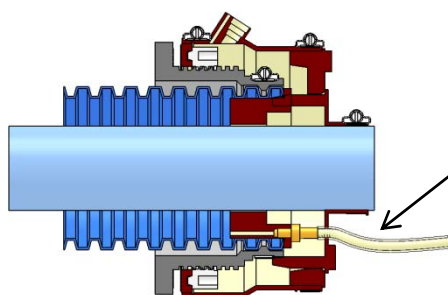

Adding an AV-3 extension to the CDS repair kit allows for a test port to pass thru the repair so that the interstice between the inside of the Corrugated ducting and the fuel carrying pipe can be monitored.

Multi-sync CDS repair with "Interstice Communication"

When ordering this option, ask the factory to drill & install the "AV-3" in the corrugated duct insert (CDI). The installing technician will need to drill a 1/4" hole in the Eccentric Insert & attach the tube to the "AV-3". The tubing needs to be bonded to the Eccentric Insert before filling.

The parts needed are :

- 1 each AV-3 Airvalve
- 1 each RFA xTube (1/4" Pellethane tubing @ 12" long)

Tubing can be ordered "By the Foot" if longer extensions are needed

- Refer to the Repair Products Price List for pricing information on these parts.

Possible Uses:

- This tubing can be left open to the sump
- Or can be connected to another fitting
- Or can be connected to some testing apparatus

Difficult to Reach Repairs

The picture to the right shows penetrations installed under a shelf in the sump wall. Many installations are severely impacted by the proximity of the leaking penetration to another barrier that may keep the filling material from being installed. The length of the gun with fill tube is often too large or cumbersome to fit into the sump.



When this is the case, the boot may be filled using a remote fill tube with accessories. The following remote fill products are available to assist in repairing difficult to reach penetrate

Remote Fill Adapter Kit & Accessories

- RFA – The **“Remote Fill Adapter”** kit can be used when it is difficult for the repair technician to reach the repaired fitting to fill it with the DBF II.
- The RFA provides a flexible 24” extension to the end of the static mixer.
- The “RFA Tubing” may be ordered in any fixed length or by the 200’ roll
- The Remote Fill accessories are available separately & must be ordered separately.

RFA: “Remote Fill Adapter” tube connected to fill port and to DAG applicator gun

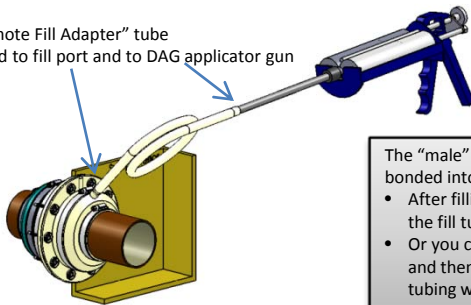

The “male” end of the RFA may be bonded into the fill port on the boot.





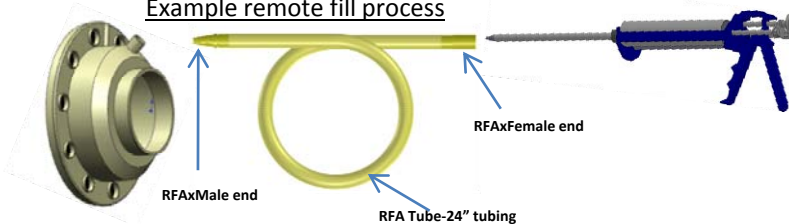

- After filling you may either just plug the fill tube and leave it in place
- Or you can cut off the excess tubing and then plug the new end of the tubing with the RFAxPlug

Example remote fill process



You will need to order extra [DBF II](#) fill when using the RFA method to fill your repair parts

Remote Fill Accessories

	RFA (Remote Fill Adapter) 24” assembly used to connect to fill port on one end & to the DAG’s Static Mixer Tube on the other end
	RFAxMale Used to connect to fill port on one end & to the RF-Tube on the other end
	RFAxFemale Used to connect to RF-Tube on one end & to the DAG on the other end
	RFA TubexTube Used to extend the length of the fill tube
	RFAxPlug Used to plug the fill port after filling with DBF II
	RFA Tube-24” (2’ long section) Stocked as standard 2’ long (Available in any length up to 200’)

When it's Wet Use Diversified's Aqua Seal (DAS)

Often the repair technician is called on to repair sites where live water is pouring into the sump. Our first experience with DPM's Aqua Seal was in the late 1990's on the east coast. The site was spitting snow and the sump was taking on water like a ¾" garden hose was opened into the sump. The technicians were having difficulty keeping up with pumping out the sump let alone doing the repairs. Aqua Seal was rushed to the scene. The repair goes like this:

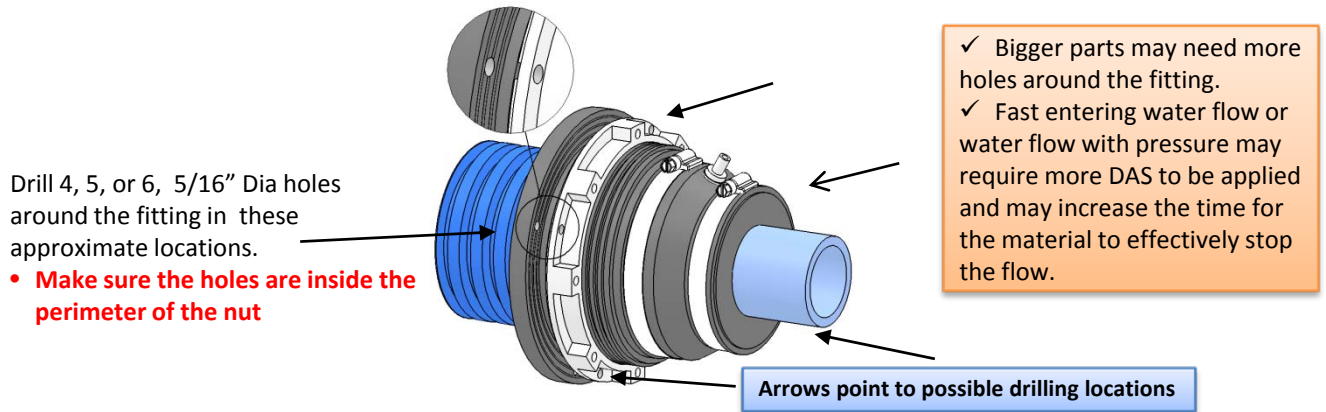

Threaded fitting with additional holes drilled for DAS Aqua-Seal

Aqua Seal (DAS) Instructions

First, drill 4, 5, or 6, 5/16" diameter holes through the flange of the existing penetration fitting directly into the soil.

- ✓ Care should be taken to drill the holes through the sump wall within the confines of the area to be encapsulated by the repair boot

Then apply the DAS thru the drilled holes.

- ✓ The hydro-active grout will provide a temporary seal behind the fitting and seal off the live water while a permanent structural repair is being performed.

Then wait for the water to stop flowing into the sump

- ✓ In the case described above it took almost 15 minutes before enough of the grout had activated to stop the live water from entering the sump.

Aqua Seal is a hydro-active grout that expands many times in the presence of water. Aqua Seal is dispensed by using a standard caulk gun.

The Caulk gun is offered by DPM as "DAG IV" and may be purchased locally or with your Aqua Seal order from DPM.

DAS Aqua Seal

DAG IV







Proper use of Applicator Guns

Diversified Products Mfg Inc utilizes two different style caulk guns. The DAG is used for DBF II and DRP, while the DAG III is used to apply DBB V. The following two pages demonstrates the use of each of these guns.

	Diversified Products Manufacturing Inc. Leaders in Innovative Products & Manufacturing Technologies	New Construction
---	---	-----------------------------

DAG

Dual Cartridge Applicator Gun Used with DBF II & DRP

<p>Warnings:</p> <ol style="list-style-type: none">1. Read the installation instructions for your project before beginning these steps2. Read MSDS sheet for this product3. Use appropriate eye and skin protection	<p>Put on safety glasses or goggles and rubber gloves.</p> 	<p>Cut off tip of static mixing tube one or two steps up tapered portion of tip.</p> 
<p>Remove cap and plugs, save them. Attach static mixer and nut.</p> 	<p>Install cartridge into gun.</p> 	<p>Purge air and some material into waste container before using.</p> 
<p>Turn gun down to dispense product. When finished, remove and discard static mixing tube.</p> 	<p>Install plugs and cap to preserve remaining product for future use.</p> 	<p>This panel left blank</p>



DAG III

Dual Cartridge Applicator Gun used with DBB V

Warnings:

1. Read the installation instructions for your project before beginning these steps
2. Read MSDS sheet for this product
3. Use appropriate eye and skin protection

Put on safety glasses or goggles and rubber gloves.



Remove cap and save.
Attach static mixer.



Install cartridge into gun.



Purge air and some material into waste container before using.



This panel left blank

Turn gun down to dispense product.
When finished, remove and discard static mixing tube.



Install cap to preserve remaining product for future use.

