

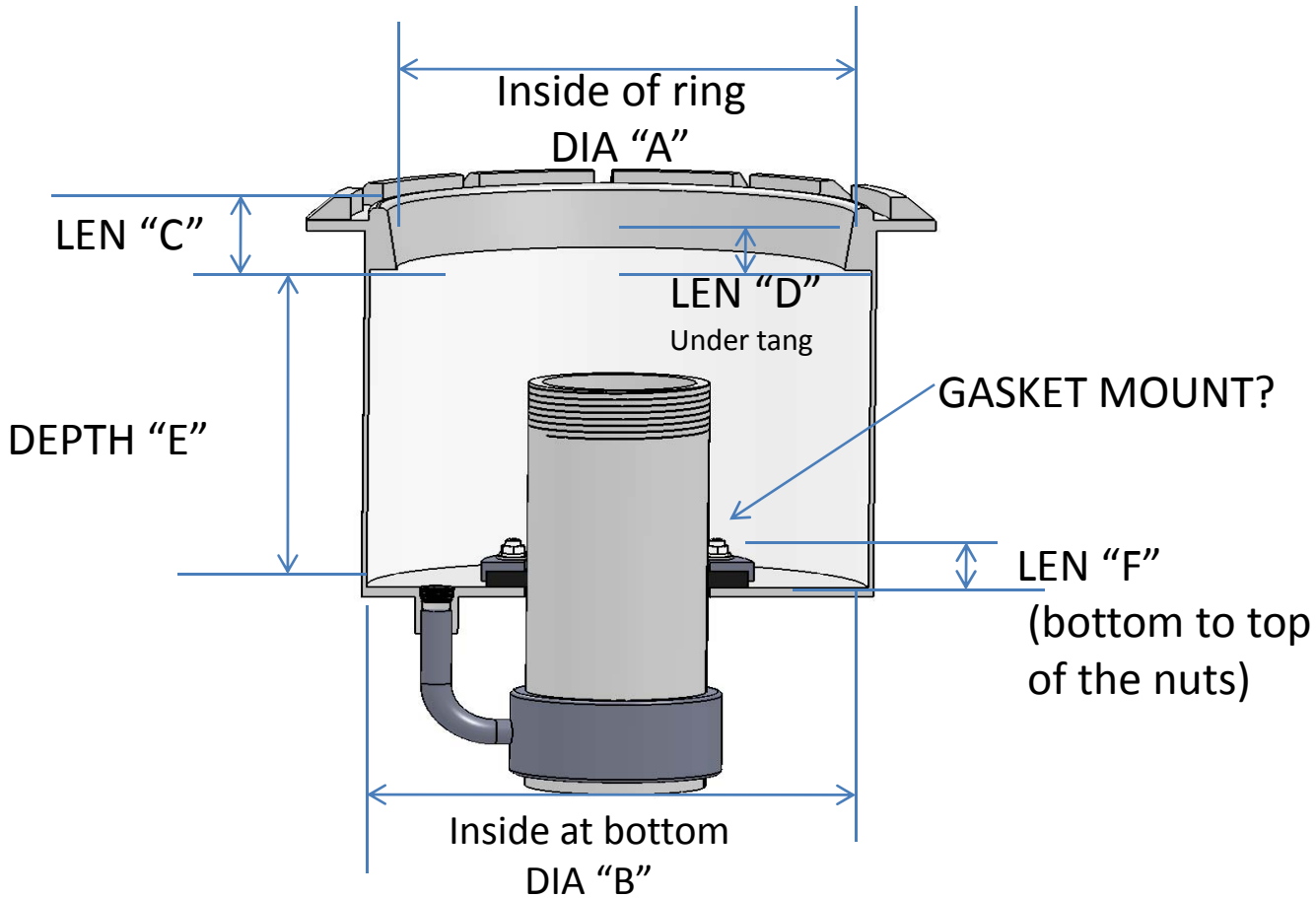

**DIVERSIFIED PRODUCTS MFG, INC**  
**MEASURING A SPILL BUCKET**

Brand \_\_\_\_\_  
 Model \_\_\_\_\_



DIA " A" \_\_\_\_\_  
 DIA "B" \_\_\_\_\_  
 LEN "C" \_\_\_\_\_  
 LEN "D"(under tang if applicable) \_\_\_\_\_  
 DEPTH "E" \_\_\_\_\_  
 LEN "F" \_\_\_\_\_  
 DRAIN VALVE Y/N?  
 THREAD IN, CLAMP DOWN \_\_\_\_\_  
 THREAD ON OR SLIP ON TYPE BUCKET \_\_\_\_\_

DPM holds no responsibility for liners when containers are not measured correctly. If you are unsure as to how to measure the container or it appears that the container is damaged or distorted in any way contact the factory for assistance. By signing this document you are authorizing DPM to Manufacture a liner to the above dimensions.

Customer Signature \_\_\_\_\_

Date \_\_\_\_\_