

# Super Sumps

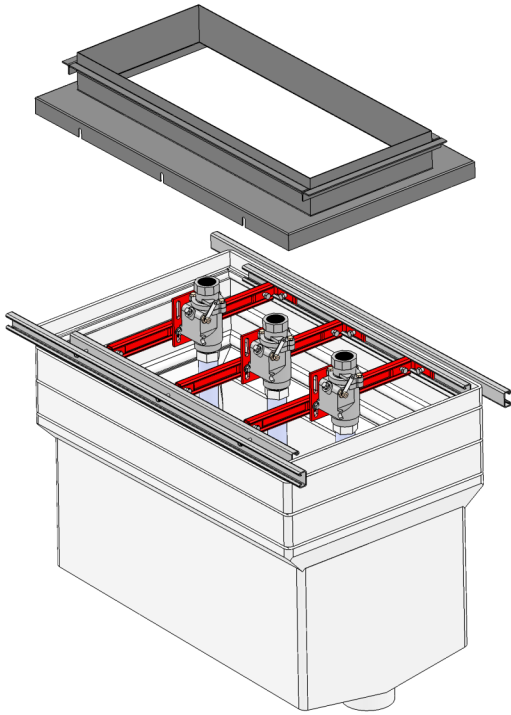

- Choice of HDPE or Fiberglass materials
- Extended warranties available
- First engineered UDC in the market place
- 3rd party approved by Ken Wilcox Associates
- Choice of traditional, grade level or transition lid
- All components available through DPM. You supply the pipe
- Optional factory installed sensor mounting bracket

- ◆ Sloped bottom for rapid leak detection
- ◆ Conduit options internal or external to the sump
- ◆ Designed for easy installation of six sumps in series
- ◆ Wide mouth for easy access
- ◆ Nest up to 4 sumps for easy shipping and handling

Approved by the  
Florida Department of  
Environmental Protection

File # EQ-742

Ask about our *Free* freight  
and prompt payment programs



Diversified Products  
Manufacturing Inc

5523 Baggett Marysville Rd  
Oroville, CA 95965

Phone: 530.534.3966  
Fax: 530.534.7404  
E-mail: [sales@dpm-llc.com](mailto:sales@dpm-llc.com)  
[www.dpm-llc.com](http://www.dpm-llc.com)

# Sump Lids



Choose from  
Traditional - Grade Level - Transition

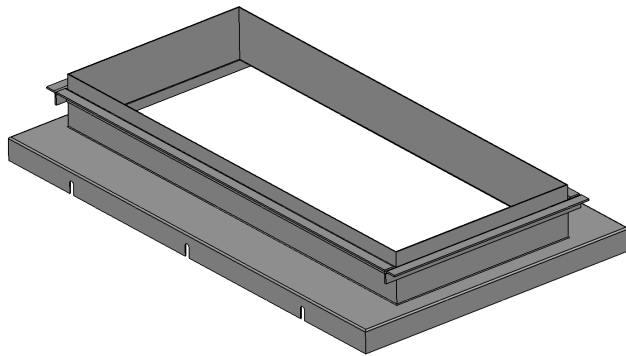

Traditional

- ◆ Designed for 3" of concrete burial
- ◆ Rugged 16 ga steel material
- ◆ Powder Coated finish
- ◆ Three standard sizes fits most dispensers

- 
- ◆ Durable fiberglass material
  - ◆ Encapsulated nuts are easily removed
  - ◆ Lid can be completely removed for maintenance and repairs
  - ◆ Two standard sizes fits most dispensers

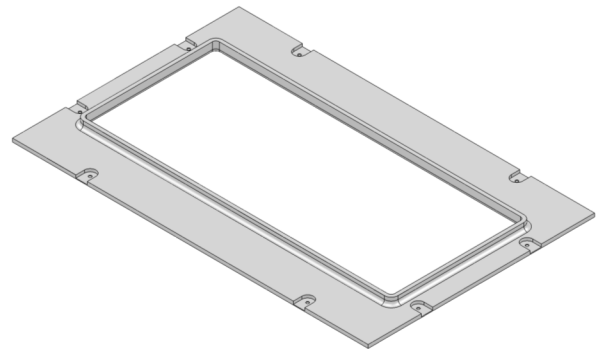

Grade Level

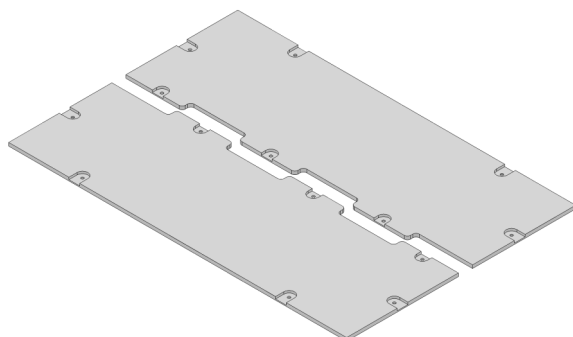

Transition

- ◆ Durable 2 pc fiberglass design
- ◆ 1/2 of the lid is easily removed for maintenance and repairs
- ◆ Suitable for below and above ground applications
- ◆ Optional H-20 rated lids are available

For more information on sumps and lids refer to  
DPM's "Check It Out" for sumps  
or  
DPM's Super Sump Application and Installation Manual