

Diversified Products
Manufacturing Inc

EBW 705 Spill
Container Liner

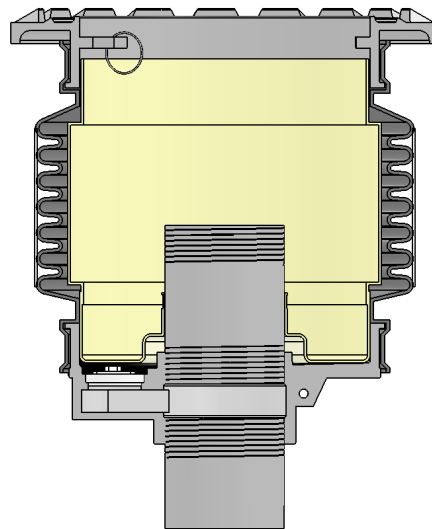

Application Bulletin

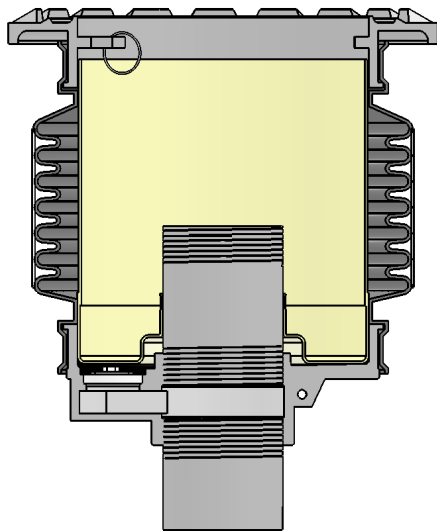

Diversified Products Manufacturing Inc
5523 Baggett Marysville Rd, Oroville, CA 95965
Ph 530.534.3966
Fax 530.534.7404
www.dpm-llc.com

Introduction

We have been accommodating where the field measurements are incorrect for fabricating the spill container liners. Up to this time we have manufactured new liners at our cost even when the dimensional data provided has been incorrect. We are unable to continue that policy. In the future order entry will only process an order when dimensional data is provided and the responsible party has signed a "release for manufacturing" form. We will try to make the form as easy to complete as possible. Should we make the product to the supplied dimensions and the liner does not fit, we would expect the purchaser to pay for the product and its replacement.

At the moment, we are most concerned with the OPW #1, OPW 2100 and the Pomeco 111 families of spill containers. These 3 families of spill containers are basically the same and they all take the exact same liner. One concern is the ability to contain 5 gallons. Our liner does slightly reduce the volume contained. However, the collapsing during installation of a 5 gallon bellows style spill container does more to reduce the container capacity than the liner.

The following is the profile of an OPW 2100 spill container in its relaxed position. We measured the volume of the spill container in its "relaxed" position as it was removed from the shipping container. The volume of the spill container in this condition is 5.75 Gallons.

We offer two versions of our liner for this product, the cylindrical and the stepped out versions. The stepped out liner has problems associated with getting the measurements correct. It is recommended that the cylindrical model be used in all instances unless the increased volume is needed. In those instances, it is imperative that we receive accurate measurements from the field. The following illustrations show the spill container volume capacity and that of DPM liners. **NOTE: DPM used a 7" riser to calculate volume, the riser you have may be different.**

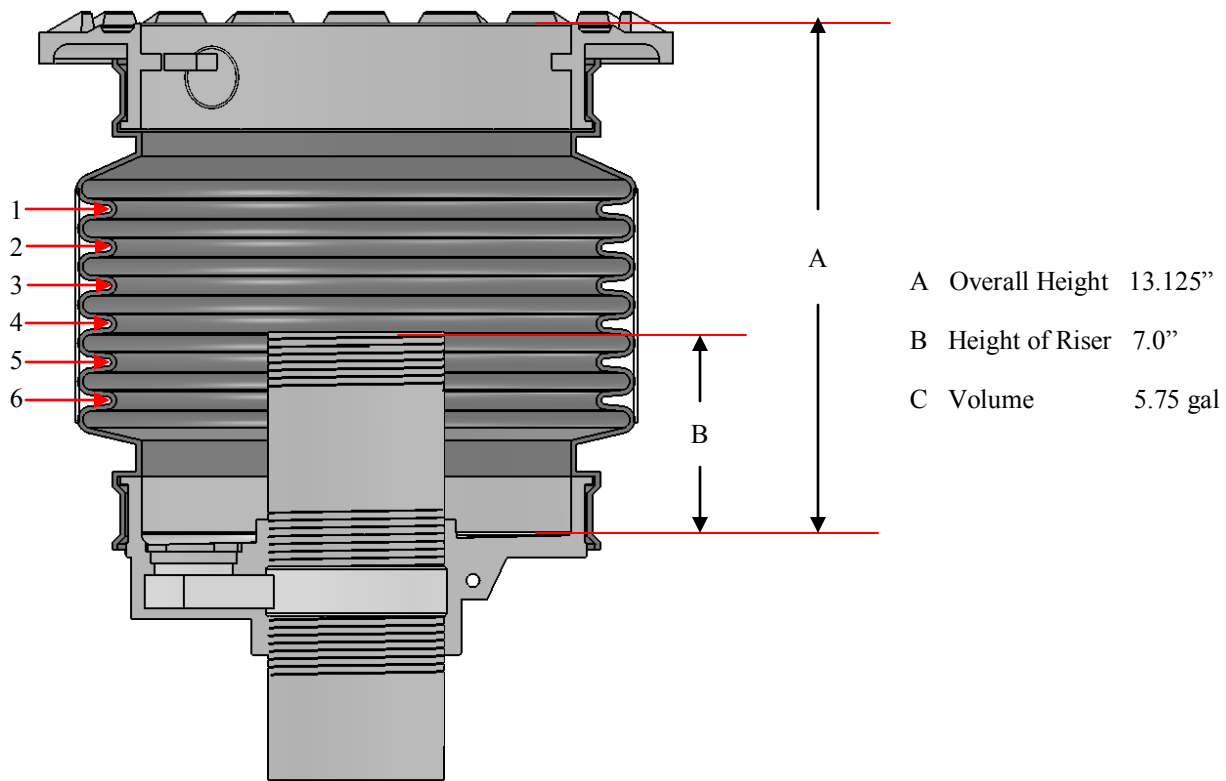

Relaxed Spill Container
as taken from shipping carton.

NOTE: This container as 6 bellows as counted from the inside

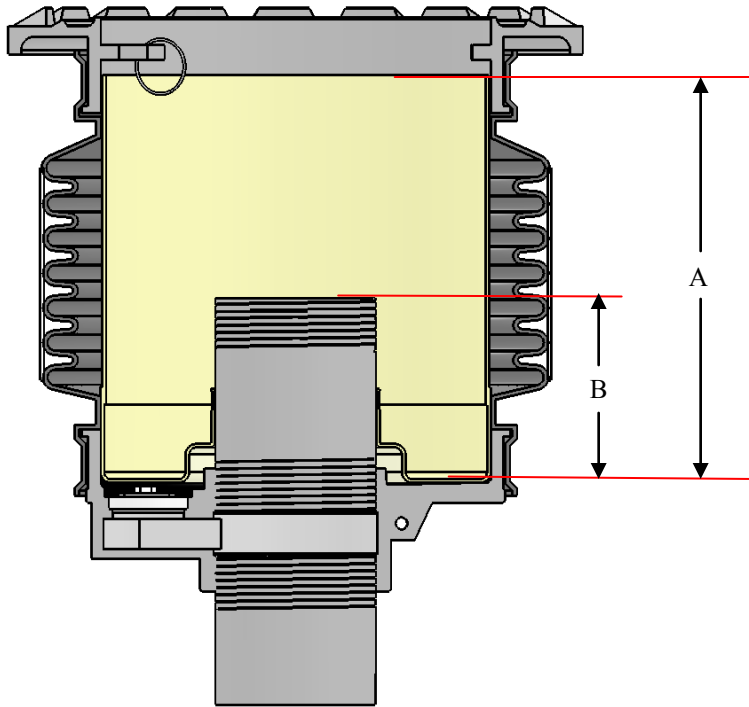

- A Height of Liner 11.5"
- B Height of Riser 7.0"
- C Volume 5.02 gal

Relaxed spill container with
DPM cylindrical liner

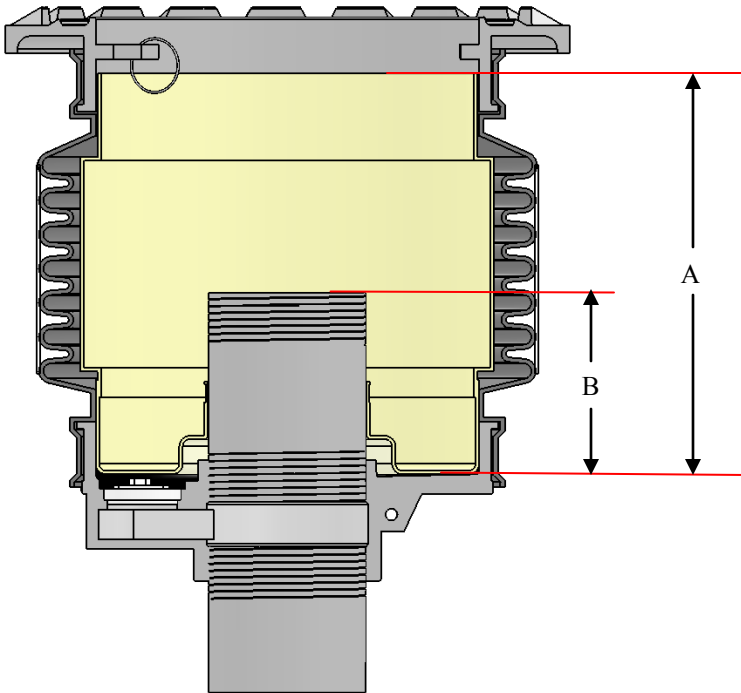

- A Height of Liner 11.5"
- B Height of Riser 7.0"
- C Volume 5.42 gal

Relaxed spill container with
DPM stepped liner

For every 1 inch of expansion or compression of the container, approximately .41 gallons is added or lost to the volume of the spill container and /or liner. This number is dependant on the height of the riser and the adapter and cap installed.

When it is necessary to provide the “stepped out” version of the liner, the following measurements need to be carefully taken. Note the bottoms should always fit, however if the top dimension is not accurately provided, then the liner will not fit.

The illustrations below show measurements of a new spill container in it’s relaxed (out of the box) condition. If you find a spill container that does not match these dimensions contact the factory.

At the end of this document is a form that is required to be completed. The purpose of this form is to ensure that DPM is manufacturing a liner to your specifications. Should you experience any problems with completing the form contact the factory for assistance. DPM will **NOT** begin manufacturing a liner until a signed copy of the form has been received.

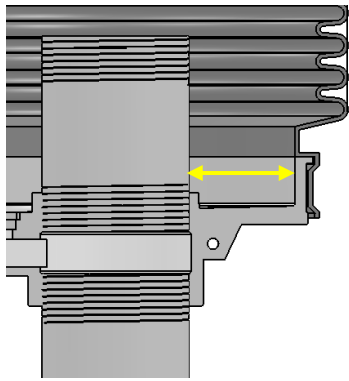

Dimension should be 3 1/4 +/- .1

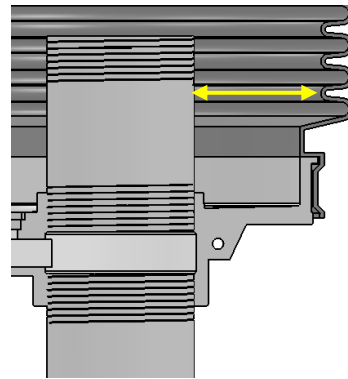

Dimension should be 3 11/16 +/- .1

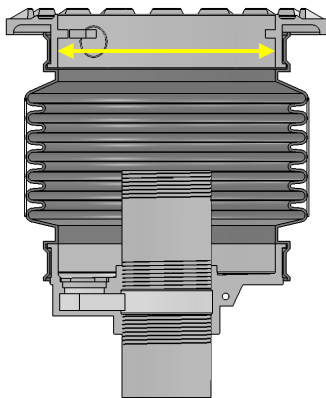

Dimension should be 11.0 +/- .1

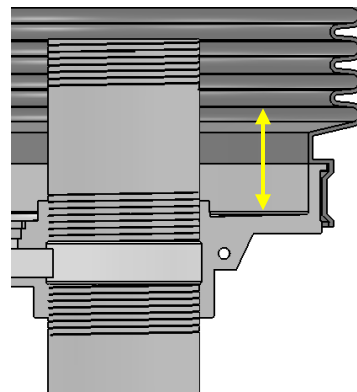

Dimension should be 3 9/16 +/- .1

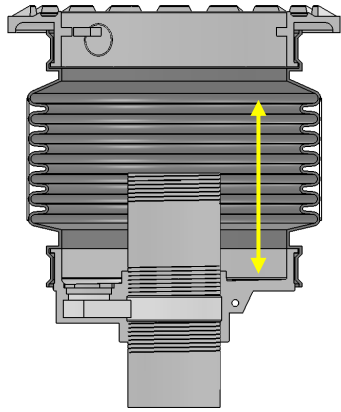

Dimension should be $8 \frac{7}{8} \pm \frac{1}{2}$

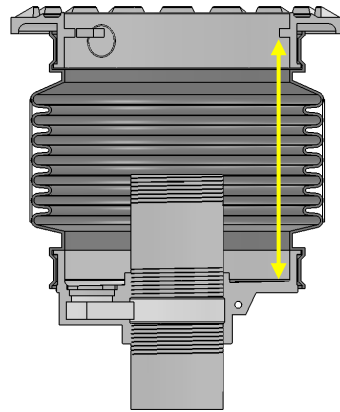

Dimension should be $11 \frac{1}{2} \pm \frac{1}{2}$

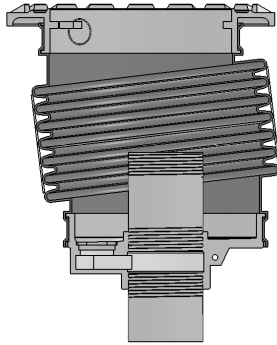

If container is in this condition
consult the factory

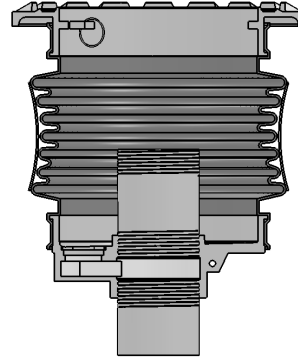

If container is in this condition
find the narrowest point

The cylindrical liner may be made longer than necessary for sealing the “relaxed” version of the liner and may be trimmed to size during installation. It is recommended you start with a new blade in your utility knife to cut the liner.

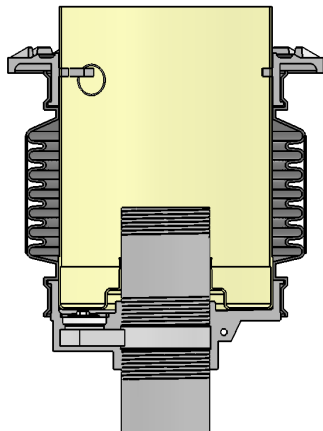

DPM oversized cylindrical
liner for relaxed container

The following technique is recommended to trim the liner in the field.

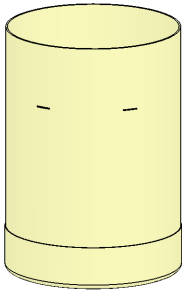

Measure from the bottom of the liner and mark in 3 or 4 places with the measurement you have from step 6 on the previous page.

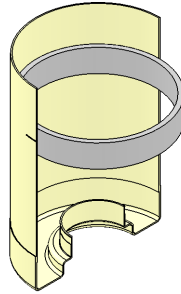

Place DPM's cutting ring tool (This item purchased separately) inside the liner with the marks lining up with the machined cutting groove on the ring.

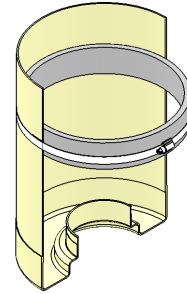

Place the provided band clamps around liner above and below the machined cutting groove.

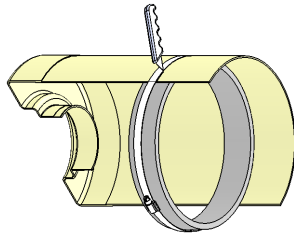

Lay the assembly on it's side and using a sharp blade cut along the cutting groove.

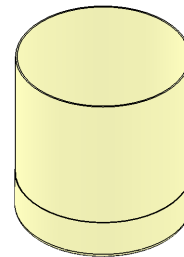

Remove the band clamps and cutting ring tool and install the liner per the installation instructions

The cutting ring tool is part of a kit that may be purchased from the factory. The kit number for this application is SCL CRK 11. The kit consists of:

- 1ea Metal ring with machined cutting groove
- 2ea 303 Stainless Steel Clamps